

Last name, first name: _____

Company address: _____

Phone: _____

Fax: _____

E-mail-address: _____

Invoice address: _____

Training company: _____

Trainer: _____

Foundation Level Sample Exam

SET A (v2.2) – GTB Edition –

CTFL Syllabus Version v4.0

ISTQB® Certified Tester Foundation Level

Legal

Copyright © 2023 International Software Testing Qualifications Board (hereinafter called ISTQB®). All rights reserved.

The authors transfer the copyright to the International Software Testing Qualifications Board (hereinafter called ISTQB®). The authors (as current copyright holders) and ISTQB® (as the future copyright holder) have agreed to the following condition of use:

Any ISTQB® Member Board may translate this document.

The ISTQB® Examination Working Group is responsible for this document.

ISTQB® Exam Working Group 2023

Acknowledgements

This document was produced by a core team from ISTQB®: Laura Albert, Wim de Coutere, Arnika Hryszko, Gary Mogyorodi, (technical reviewer), Meile Posthuma, Gandhinee Rajkomar, Stuart Reid, Jean-François Riverin, Adam Roman, Lucjan Stapp, Stephanie Ulrich, Yaron Tsubery and Eshraka Zakaria.

The core team thanks the review team: Amanda Alderman, Alexander Alexandrov, Jürgen Beniermann, Rex Black, Young jae Choi, Nicola De Rosa, Klaudia Dussa-Zieger, Klaus Erlenbach, Joëlle Genois, Tamás Gergely, Dot Graham, Matthew Gregg, Gabriele Haller, Chinthaka Indikadahena, John Kurowski, Ine Lutterman, Isabelle Martin, Patricia McQuaid, Dénes Medzihradzsky, Blair Mo, Gary Mogyorodi, Jörn Münzel, Markus Niehammer, Ingvar Nordström, Fran O'Hara, Raul Onisor, Dénes Orosz, Arnd Pehl, Horst Pohlmann, Nishan Portoyan, Ale Rebon Portillo, Stuart Reid, Ralf Reissing, Liang Ren, Jean-Francois Riverin, Lloyd Roden, Tomas Rosenqvist, Murian Song, Szilard Szell, Giancarlo Tomasig, Joanne Tremblay, François Vaillancourt, Daniel van der Zwan, André Verschelling and Paul Weymouth.

Revision History

| Version | Date | Remarks |
|---------|------------|--|
| 1.0 | 12.04.2023 | Release version |
| 2.1 | 15.10.2023 | Revision by GTB AG Exam (arrangement of questions changed, roman type questions eliminated, questions replaced and modified), revision after BETA reviews by GTB members, TAG and university lecturers. Final GTB edition |
| 2.2 | 16.02.2025 | Rework by Native Speaker Review |

Introduction

This is a sample exam. It helps candidates to prepare for the actual certification exam. Questions are included whose structure, layout and format are like a regular ISTQB®/ GTB Certified Tester Foundation Level exam. It is strictly forbidden to use the exam questions as content of a certification exam.

- 1) Any individual or training provider may use this sample exam in a training course if ISTQB® is acknowledged as the source and copyright holder of the sample exam.
- 2) Any individual or group of individuals may use this sample exam as the basis for articles, books or other derivative writings if ISTQB® is acknowledged as the source and copyright holder of the sample exam.
- 3) Any national board recognized by ISTQB® may translate this sample exam and make it publicly available if ISTQB® is acknowledged as the source and copyright holder of the sample exam.
- 4) Exactly one correct solution is expected for almost every question. The exceptions explicitly mention the possibility of multiple answers.

Exam notes

Number of questions: 40

Duration of the exam: 60 minutes

Total score: 40 (one point per question)

Score to pass the exam: 26 (or more)

Percentage of passing the exam: 65% (or more)

Feedback on this sample exam as a whole (40 questions) or on individual questions was provided in the German-language BETA versions of SET A in the period June - August 2023 by: Armin Born (STB), Bettina Buth (HS-Anhalt), Klaus Erlenbach (imbus AG), Sabine Gschwandtner (imbus), Michaela Huhn (HS Ostfalia), Jörn Münzel (former GTB), Paul Müller (SQL/ATB), Reto Müller (STB), Arnd Pehl (imbus AG), Horst Pohlmann (GTB/TH-OWL), Stephan Weissleder (GTB), Marc-Florian Wendland (GTB), Volkmar Richter (HS Anhalt), Ralf Reissing (GTB/Hochschule Coburg).

The preparation of the English version was supported by Ecaterina Irina Manole, Debra Friedenberg and Horst Pohlmann.

Note: Compared to the original English version, considerable adaptations have been made; some questions have also been replaced.

| | | | |
|-------------------|-----------------|-----------|------------------|
| Question 1 | FL-1.1.1 | K1 | Score 1.0 |
|-------------------|-----------------|-----------|------------------|

Which of the following statements describes an achievable test objective?

Please choose ONE option! (1 out of 4)

| | | |
|----|---|--------------------------|
| a) | To prove that there are no unfixed defects in the system under test. | <input type="checkbox"/> |
| b) | To prove that there will be no failures after the system is put into production. | <input type="checkbox"/> |
| c) | To reduce the risk level of the test object and to build confidence in the quality level. | <input type="checkbox"/> |
| d) | To verify that there are no untested combinations of inputs. | <input type="checkbox"/> |

| | | | |
|-------------------|-----------------|-----------|------------------|
| Question 2 | FL-1.1.2 | K2 | Score 1.0 |
|-------------------|-----------------|-----------|------------------|

What is the main difference between testing and debugging?

Please choose ONE option! (1 out of 4)

| | | |
|----|---|--------------------------|
| a) | Testing is the process of finding defects, while debugging is the process of fixing defects. | <input type="checkbox"/> |
| b) | Testing verifies requirements, while debugging verifies design. | <input type="checkbox"/> |
| c) | Testing is the process of running software, while debugging is the process of analyzing the software. | <input type="checkbox"/> |
| d) | Testing is the process of defect prevention, while debugging is the process of defect elimination. | <input type="checkbox"/> |

| | | | | |
|------------|----------|----|-------|-----|
| Question 3 | FL-1.3.1 | K2 | Score | 1.0 |
|------------|----------|----|-------|-----|

You are part of a team testing a new system. You've noticed that no changes have been made to the existing regression test cases for several iterations, and no new bugs have been uncovered by regression testing. Your manager is satisfied, but you are not.

Which testing principle best explains your skepticism?

Please choose ONE option! (1 out of 4)

| | | |
|----|-----------------------------------|--------------------------|
| a) | Old tests become less effective. | <input type="checkbox"/> |
| b) | Absence-of-errors fallacy. | <input type="checkbox"/> |
| c) | Defects cluster together. | <input type="checkbox"/> |
| d) | Exhaustive testing is impossible. | <input type="checkbox"/> |

| | | | | |
|------------|----------|----|-------|-----|
| Question 4 | FL-1.4.1 | K2 | Score | 1.0 |
|------------|----------|----|-------|-----|

You work in a team that develops a mobile application for ordering food. The team decides to implement the payment functionality during the current iteration.

Which of the following activities is a part of test analysis?

Please choose ONE option! (1 out of 4)

| | | |
|----|---|--------------------------|
| a) | Perform the effort estimation for testing the integration of the mobile application with the payment service. | <input type="checkbox"/> |
| b) | Decide whether to test the ability to split payments among multiple users. | <input type="checkbox"/> |
| c) | Using boundary value analysis (BVA) to derive the test data for the test cases that check for correct payment processing on the minimum allowable payment amount. | <input type="checkbox"/> |
| d) | Analysis of the deviation between the actual and the expected result after the execution of a test case. | <input type="checkbox"/> |

| | | | | |
|------------|----------|----|-------|-----|
| Question 5 | FL-1.4.4 | K2 | Score | 1.0 |
|------------|----------|----|-------|-----|

Which of the following statements BEST describes how value is added by establishing and maintaining traceability between the test base and the test ware?

Please choose ONE option! (1 out of 4)

| | | |
|----|---|--------------------------|
| a) | Maintenance testing can be fully automated on the basis of changes to the original requirements. | <input type="checkbox"/> |
| b) | Whether or not the targeted coverage has been achieved can be more efficiently determined. | <input type="checkbox"/> |
| c) | The test management role can determine which testers found the defects with the highest severity. | <input type="checkbox"/> |
| d) | Code areas that may be affected by side effects of a change can be targeted through regression testing. | <input type="checkbox"/> |

| | | | | |
|------------|----------|----|-------|-----|
| Question 6 | FL-1.4.5 | K2 | Score | 1.0 |
|------------|----------|----|-------|-----|

Which of the following statements BEST describes the differences between testing roles?

Please choose ONE option! (1 out of 4)

| | | |
|----|--|--------------------------|
| a) | The testing role executes test cases, the test management role plans and monitors the testing activities and reports the deviation to all testers. | <input type="checkbox"/> |
| b) | The testing role performs test analysis and test design activities, creates and executes test cases, and the test management role coordinates testing resources and reports to stakeholders. | <input type="checkbox"/> |
| c) | The testing role decides the tests to be automated and prioritizes test cases, and the test management role analyzes risks and prioritizes tests. | <input type="checkbox"/> |
| d) | The testing role performs static and dynamic component testing, and the test management role performs system testing and acceptance testing. | <input type="checkbox"/> |

| | | | | |
|------------|----------|----|-------|-----|
| Question 7 | FL-1.5.3 | K2 | Score | 1.0 |
|------------|----------|----|-------|-----|

Which of the following BEST explains a benefit of independence of testing?

Please choose ONE option! (1 out of 4)

| | | |
|----|---|--------------------------|
| a) | The use of an independent test team allows project management to assign responsibility for the quality of the final deliverable to the test team. | <input type="checkbox"/> |
| b) | If a test team external to the organization is used, then the external team will not be as easily influenced by project management delivery concerns and the need to meet strict delivery deadlines. | <input type="checkbox"/> |
| c) | An independent test team can work separately from the developers, need not be distracted with project requirement changes, and can restrict communication with the developers to defect reporting through the defect management system. | <input type="checkbox"/> |
| d) | When specifications contain ambiguities and inconsistencies, assumptions are made by developers on their interpretation, and an independent test team can be useful in questioning those assumptions and interpretations. | <input type="checkbox"/> |

| | | | | |
|-------------------|-----------------|-----------|--------------|------------|
| Question 8 | FL-1.5.2 | K1 | Score | 1.0 |
|-------------------|-----------------|-----------|--------------|------------|

How is the whole team approach present in the interactions between testers and business representatives?

Please choose ONE option! (1 out of 4)

| | | |
|----|---|--------------------------|
| a) | Business representatives decide together with project management on test automation approaches. | <input type="checkbox"/> |
| b) | Testers help business representatives to define test strategy. | <input type="checkbox"/> |
| c) | Business representatives are not part of the whole team approach. | <input type="checkbox"/> |
| d) | Testers help business representatives to create suitable acceptance tests. | <input type="checkbox"/> |

| | | | | |
|-------------------|-----------------|-----------|--------------|------------|
| Question 9 | FL-2.1.2 | K2 | Score | 1.0 |
|-------------------|-----------------|-----------|--------------|------------|

Which of the following statements BEST describes a good practice for testing that applies to all software development lifecycles?

Please choose ONE option! (1 out of 4)

| | | |
|----|--|--------------------------|
| a) | Testing should be performed only after development is complete. | <input type="checkbox"/> |
| b) | Testing should be performed under the leadership of development. | <input type="checkbox"/> |
| c) | Testing should start early in the development process. | <input type="checkbox"/> |
| d) | Testing should be performed in a development test environment. | <input type="checkbox"/> |

| | | | |
|--------------------|-----------------|-----------|------------------|
| Question 10 | FL-2.1.3 | K1 | Score 1.0 |
|--------------------|-----------------|-----------|------------------|

Which of the following statements BEST describes the acceptance test-driven development (ATDD) approach?

Please choose ONE option! (1 out of 4)

| | | |
|----|---|--------------------------|
| a) | In ATDD, acceptance criteria are typically created based on the given/when/then format. | <input type="checkbox"/> |
| b) | In ATDD, test cases are developed first and then the software is implemented incrementally against the test cases and defined acceptance criteria. | <input type="checkbox"/> |
| c) | In ATDD, tests are derived from acceptance criteria as part of the system design. | <input type="checkbox"/> |
| d) | With ATDD, tests are based on the desired behavior of the software, which makes it easier for team members to understand the tests and the defined acceptance criteria. | <input type="checkbox"/> |

| | | | |
|--------------------|-----------------|-----------|------------------|
| Question 11 | FL-2.1.5 | K2 | Score 1.0 |
|--------------------|-----------------|-----------|------------------|

Which of the following is NOT an example of the shift left approach?

Please choose ONE option! (1 out of 4)

| | | |
|----|--|--------------------------|
| a) | Reviewing the user requirements before they are formally accepted by the stakeholders. | <input type="checkbox"/> |
| b) | Create component test cases before programming the associated code. | <input type="checkbox"/> |
| c) | Executing a performance efficiency test for a component during component testing. | <input type="checkbox"/> |
| d) | Begin the execution of non-functional tests during system level testing. | <input type="checkbox"/> |

| | | | | |
|-------------|----------|----|-------|-----|
| Question 12 | FL-2.1.6 | K2 | Score | 1.0 |
|-------------|----------|----|-------|-----|

Which of the arguments below would you use to convince your manager to hold retrospectives at the end of each release cycle?

Please choose ONE option! (1 out of 4)

| | | |
|----|---|--------------------------|
| a) | Retrospectives are very popular these days and clients would appreciate it if we added them to our processes. | <input type="checkbox"/> |
| b) | Performing regular retrospectives will save the organization money because end user representatives do not provide immediate feedback about the product. | <input type="checkbox"/> |
| c) | Process weaknesses identified during the retrospective can be analyzed and serve as a to-do list for the organization's continuous process improvement program. | <input type="checkbox"/> |
| d) | Retrospectives embrace the five values including courage and respect, which are crucial to maintain continuous improvement in the organization. | <input type="checkbox"/> |

| | | | | |
|-------------|----------|----|-------|-----|
| Question 13 | FL-2.2.1 | K2 | Score | 1.0 |
|-------------|----------|----|-------|-----|

Which types of defects (1-4) fit which test levels (A-D) BEST?

- 1. Defects in system behavior as it deviates from the user's business needs.**
- 2. Defects in communication between components.**
- 3. Defects in an isolated component.**
- 4. Defects in an incorrectly implemented user story.**

- A. Component testing**
- B. Component Integration testing**
- C. System testing**
- D. Acceptance testing**

Please choose ONE option! (1 out of 4)

| | | |
|----|----------------|--------------------------|
| a) | 1D, 2B, 3A, 4C | <input type="checkbox"/> |
| b) | 1D, 2B, 3C, 4A | <input type="checkbox"/> |
| c) | 1B, 2A, 3D, 4C | <input type="checkbox"/> |
| d) | 1C, 2A, 3B, 4D | <input type="checkbox"/> |

| | | | | |
|-------------|----------|----|-------|-----|
| Question 14 | FL-2.3.1 | K2 | Score | 1.0 |
|-------------|----------|----|-------|-----|

Your organization's test strategy suggests that once a system is planned for retirement, data migration to a new system shall be tested.

As part of what test activity is this testing MOST likely to be performed?

Please choose ONE option! (1 out of 4)

| | | |
|----|-------------------------------|--------------------------|
| a) | Maintenance testing | <input type="checkbox"/> |
| b) | Regression testing | <input type="checkbox"/> |
| c) | Component testing | <input type="checkbox"/> |
| d) | Component integration testing | <input type="checkbox"/> |

| | | | | |
|-------------|----------|----|-------|-----|
| Question 15 | FL-3.1.2 | K2 | Score | 1.0 |
|-------------|----------|----|-------|-----|

Which of the following is NOT a benefit of static testing?

Please choose ONE option! (1 out of 4)

| | | |
|----|---|--------------------------|
| a) | Evaluating and remediating anomalies discovered through static analysis can take a significant amount of time and resources. | <input type="checkbox"/> |
| b) | Fixing defects found during static testing is generally much less expensive than fixing defects found during dynamic testing. | <input type="checkbox"/> |
| c) | Finding coding defects that might not have been found by only performing dynamic testing. | <input type="checkbox"/> |
| d) | Detecting gaps and inconsistencies in requirements. | <input type="checkbox"/> |

| | | | | |
|-------------|----------|----|-------|-----|
| Question 16 | FL-3.2.1 | K1 | Score | 1.0 |
|-------------|----------|----|-------|-----|

Which of the following is a benefit of early and frequent feedback by stakeholders?

Please choose ONE option! (1 out of 4)

| | | |
|----|---|--------------------------|
| a) | It improves the test process for future projects. | <input type="checkbox"/> |
| b) | It forces customers to prioritize their requirements based on agreed risks. | <input type="checkbox"/> |
| c) | It is the only way to measure the quality of changes. | <input type="checkbox"/> |
| d) | It helps avoid requirements misunderstandings. | <input type="checkbox"/> |

| | | | | |
|-------------|----------|----|-------|-----|
| Question 17 | FL-3.2.4 | K2 | Score | 1.0 |
|-------------|----------|----|-------|-----|

Your organization's reviews have the following characteristics:

- **The main purpose is to communicate or train reviewers.**
- **The meeting is led by the author of the work product.**
- **There is individual independently preparation of the reviewer before the meeting.**
- **A review report is produced.**

Which of the following review types is MOST likely being used?

Please choose ONE option! (1 out of 4)

| | | |
|----|------------------|--------------------------|
| a) | Informal review | <input type="checkbox"/> |
| b) | Walkthrough | <input type="checkbox"/> |
| c) | Technical review | <input type="checkbox"/> |
| d) | Inspection | <input type="checkbox"/> |

| | | | |
|--------------------|-----------------|-----------|------------------|
| Question 18 | FL-3.2.5 | K1 | Score 1.0 |
|--------------------|-----------------|-----------|------------------|

Which of these statements is NOT a factor that contributes to successful reviews?

Please choose ONE option! (1 out of 4)

| | | |
|----|--|--------------------------|
| a) | Participants should dedicate adequate time for the review. | <input type="checkbox"/> |
| b) | Splitting large work products into small parts is recommended so that reviewers (reviewers) do not lose focus. | <input type="checkbox"/> |
| c) | Establishing clear objectives and measurable exit criteria for the review. | <input type="checkbox"/> |
| d) | Management's personal involvement in communicating findings. | <input type="checkbox"/> |

| | | | |
|--------------------|-----------------|-----------|------------------|
| Question 19 | FL-4.1.1 | K2 | Score 1.0 |
|--------------------|-----------------|-----------|------------------|

Which of the following is a characteristic of experience-based test techniques?

Please choose ONE option! (1 out of 4)

| | | |
|----|--|--------------------------|
| a) | Test cases are created based on detailed design information. | <input type="checkbox"/> |
| b) | The number of interfaces tested is used to measure the coverage. | <input type="checkbox"/> |
| c) | The techniques heavily rely on the tester's knowledge of the software and the business domain. | <input type="checkbox"/> |
| d) | The test cases are used to identify deviations from the requirements. | <input type="checkbox"/> |

| | | | | |
|-------------|----------|----|-------|-----|
| Question 20 | FL-4.2.1 | K3 | Score | 1.0 |
|-------------|----------|----|-------|-----|

You are testing the software for a self-service American gas pump. After lifting the nozzle and selecting the desired grade of fuel, the customer enters the desired amount of fuel in gallons using a keypad. The keypad allows only numeric entry. Between 0.1 and 50.0 gallons can be dispensed per fill-up.

Which of the following answers represents a minimum set of input values that covers all valid and invalid fuel quantity equivalence partitions?

Please choose ONE option! (1 out of 4)

| | | |
|----|----------------------------------|--------------------------|
| a) | 0.0; 20.0; 60.0 | <input type="checkbox"/> |
| b) | 0.0; 0.1; 50.0 | <input type="checkbox"/> |
| c) | 0.0; 0.1; 50.0; 70.0 | <input type="checkbox"/> |
| d) | -0.1; 0.0; 0.1; 49.9; 50.0; 50.1 | <input type="checkbox"/> |

| | | | | |
|-------------|----------|----|-------|-----|
| Question 21 | FL-4.2.2 | K3 | Score | 1.0 |
|-------------|----------|----|-------|-----|

You are testing an e-commerce system that sells bulk food items such as spices, flour, and sugar. The units in which the items are sold are either grams or kilograms. Regardless of the units, the smallest valid order quantity is 0.5 units (e. g., half a gram of cardamom pods) and the largest valid order quantity is 25.0 units (e. g., 25 kilograms of sugar). The order quantity can be incremented in 0.1 units.

Which of the following input values cover only the limits with 2-value limit analysis for the order quantity?

Please choose ONE option! (1 out of 4)

| | | |
|----|--------------------------------|--------------------------|
| a) | 0.3; 24.9; 25.2 | <input type="checkbox"/> |
| b) | 0.4; 0.5; 0.6; 24.9;25.0; 25.1 | <input type="checkbox"/> |
| c) | 0.4; 0.5; 25.0; 25.1 | <input type="checkbox"/> |
| d) | 0.5; 0.6; 24.9; 25.0 | <input type="checkbox"/> |

| | | | | |
|-------------|----------|----|-------|-----|
| Question 22 | FL-4.2.3 | K3 | Score | 1.0 |
|-------------|----------|----|-------|-----|

Newly hired employees of a company can agree on individual goals with their superiors, the achievement of which is linked to their bonus. However, this bonus is only paid to them if they have been employed by the company for more than one year.

This situation can be illustrated in a decision table:

| Test Case-ID | | T1 | T2 | T3 | T4 | T5 |
|--------------|----------------------------------|-----|----|-----|-----|-----|
| Condition1 | Employment longer than one year? | YES | NO | NO | YES | NO |
| Condition2 | Target goal agreed? | NO | NO | YES | YES | YES |
| Condition3 | Target goal achieved? | NO | NO | YES | YES | NO |
| Action | Payment of the bonus? | NO | NO | NO | YES | NO |

Which of the following test cases describes a real-world situation that is missing from the above decision table?

Please choose ONE option! (1 out of 4)

| | | |
|----|---|--------------------------|
| a) | Condition1 = YES, Condition2 = NO, Condition3 = YES, Action = NO | <input type="checkbox"/> |
| b) | Condition1 = YES, Condition2 = YES, Condition3 = NO, Action = YES | <input type="checkbox"/> |
| c) | Condition1 = NO, Condition2 = NO, Condition3 = YES, Action = NO | <input type="checkbox"/> |
| d) | Condition1 = YES, Condition2 = YES, Condition3 = NO, Action = NO | <input type="checkbox"/> |

| | | | |
|--------------------|-----------------|-----------|------------------|
| Question 23 | FL-4.2.4 | K3 | Score 1.0 |
|--------------------|-----------------|-----------|------------------|

Which of the following statements about the state transition diagram and test case table below is TRUE?

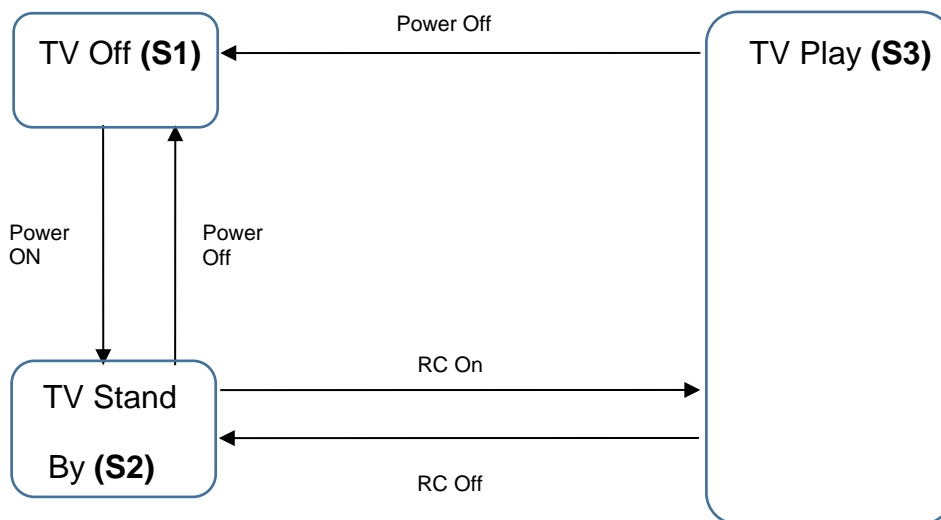

| Test case | 1 | 2 | 3 | 4 | 5 |
|---------------|----------|-----------|-------|--------|-----------|
| Initial state | S1 | S2 | S2 | S3 | S3 |
| Input | Power On | Power Off | RC On | RC Off | Power Off |
| Final state | S2 | S1 | S3 | S2 | S1 |

Please choose ONE option! (1 out of 4)

| | | |
|----|--|--------------------------|
| a) | The test cases execute all transitions in the state transition diagram, achieving 100% coverage of all transitions. | <input type="checkbox"/> |
| b) | The test cases execute all valid transitions in the state transition diagram. This achieves 100% 0-switch coverage. | <input type="checkbox"/> |
| c) | The test cases execute only some of the valid transitions in the state transition diagram. Therefore, the 0-switch coverage is less than 100%. | <input type="checkbox"/> |
| d) | Test Case 2 is not required for 100% 0-switch coverage, since state S1 is already covered by Test Case 5. | <input type="checkbox"/> |

| | | | | |
|--------------------|-----------------|-----------|--------------|------------|
| Question 24 | FL-4.3.1 | K2 | Score | 1.0 |
|--------------------|-----------------|-----------|--------------|------------|

Which of the following describes statement coverage?

Please choose ONE option! (1 out of 4)

| | | |
|----|---|--------------------------|
| a) | It is a metric for calculating and measuring the percentage of test cases executed. | <input type="checkbox"/> |
| b) | It is a metric that indicates the percentage of statements in the code that have been executed by test cases. | <input type="checkbox"/> |
| c) | It is a metric for measuring the number of statements in the code executed by test cases that did not reveal a failure. | <input type="checkbox"/> |
| d) | It is a metric that provides true/false confirmation that all statements are covered by executed test cases. | <input type="checkbox"/> |

| | | | | |
|--------------------|-----------------|-----------|--------------|------------|
| Question 25 | FL-4.3.3 | K2 | Score | 1.0 |
|--------------------|-----------------|-----------|--------------|------------|

Which of the following statements is NOT true for white-box testing?

Please choose ONE option! (1 out of 4)

| | | |
|----|--|--------------------------|
| a) | White-box testing is testing based on the analysis of the internal structure of a component or system. | <input type="checkbox"/> |
| b) | White-box coverage metrics can help identify additional tests to increase code coverage. | <input type="checkbox"/> |
| c) | White-box testing techniques can be used in addition to black-box testing techniques to increase confidence in the code. | <input type="checkbox"/> |
| d) | White-box testing can help identify unimplemented requirements. | <input type="checkbox"/> |

| | | | | |
|-------------|----------|----|-------|-----|
| Question 26 | FL-4.4.1 | K2 | Score | 1.0 |
|-------------|----------|----|-------|-----|

Which of the following BEST describes the concept behind error guessing?

Please choose ONE option! (1 out of 4)

| | | |
|----|---|--------------------------|
| a) | Error guessing involves using your knowledge and experience of past defects and failures, and typical errors made by developers. | <input type="checkbox"/> |
| b) | Error guessing involves using your personal experience of development and the errors you previously made as a developer. | <input type="checkbox"/> |
| c) | Error guessing requires you to imagine that you are the user of the test object and to guess errors the user might make while interacting with it. | <input type="checkbox"/> |
| d) | Error guessing requires you, as a tester, to duplicate the development tasks so that defects and failures a developer might make can be identified. | <input type="checkbox"/> |

| | | | | |
|-------------|----------|----|-------|-----|
| Question 27 | FL-4.4.2 | K2 | Score | 1.0 |
|-------------|----------|----|-------|-----|

The release of a brand-new application has been delayed and testing has started late, but you have very detailed domain knowledge and good analytical skills. The full requirements specification has not yet been shared with you, and management is asking for early test results.

What is the BEST test technique to use in this situation?

Please choose ONE option! (1 out of 4)

| | | |
|----|-------------------------|--------------------------|
| a) | Checklist-based testing | <input type="checkbox"/> |
| b) | Error guessing | <input type="checkbox"/> |
| c) | Exploratory testing | <input type="checkbox"/> |
| d) | Branch testing | <input type="checkbox"/> |

| | | | | |
|-------------|----------|----|-------|-----|
| Question 28 | FL-4.5.2 | K2 | Score | 1.0 |
|-------------|----------|----|-------|-----|

Which of the following activities describes the BEST way to formulate acceptance criteria for a given user story?

Please choose ONE option! (1 out of 4)

| | | |
|----|--|--------------------------|
| a) | Performing retrospectives to determine the actual needs of the stakeholders. | <input type="checkbox"/> |
| b) | Using the given/when/then format to describe an example test condition. | <input type="checkbox"/> |
| c) | Using verbal communication to reduce the risk of misunderstanding the acceptance criteria by others. | <input type="checkbox"/> |
| d) | Documenting risks related to a given user story in a test plan to facilitate the risk-based testing. | <input type="checkbox"/> |

| | | | | |
|-------------|----------|----|-------|-----|
| Question 29 | FL-4.5.3 | K3 | Score | 1.0 |
|-------------|----------|----|-------|-----|

Your team is following the Acceptance Test-Driven Development (ATDD) approach and analyzes the following user-story to create test cases.

As a registered customer, I want to be able to view my past orders on the company's website to keep track of my purchases.

Your team has identified the following list of test cases. Which of the test cases is NOT relevant to this user-story?

Please choose ONE option! (1 out of 4)

| | | |
|----|--|--------------------------|
| a) | Input: The customer logs into their account on the website and clicks the "View Order History" button. Expected output: The system displays a list of all the customers' previous orders, including date, order number, and total cost. | <input type="checkbox"/> |
| b) | Input: The logged-in customer clicks on an order in the list of his orders. Expected output: The system displays each purchased item with price and quantity. | <input type="checkbox"/> |
| c) | Input: The logged-in customer clicks the "Sort Ascending" button on the order history screen. Expected output: The system displays the order history sorted in ascending order by order number. | <input type="checkbox"/> |
| d) | Input: A newly registered customer logs in and enters a first order. Expected output: The system accepts the order and stores the associated data. | <input type="checkbox"/> |

| | | | |
|--------------------|-----------------|-----------|------------------|
| Question 30 | FL-5.1.2 | K1 | Score 1.0 |
|--------------------|-----------------|-----------|------------------|

How do testers add value to iteration and release planning?

Please choose ONE option! (1 out of 4)

| | | |
|----|--|--------------------------|
| a) | Testers determine the priority of the user stories to be developed. | <input type="checkbox"/> |
| b) | Testers focus only on refining the functional aspects of the system under test. | <input type="checkbox"/> |
| c) | Testers participate in risk analysis and determine testability of user stories. | <input type="checkbox"/> |
| d) | Testers enable the release of high-quality software through early test design during release planning. | <input type="checkbox"/> |

| | | | |
|--------------------|-----------------|-----------|------------------|
| Question 31 | FL-5.1.3 | K2 | Score 1.0 |
|--------------------|-----------------|-----------|------------------|

Which ONE of the following options is an exit criterion for testing a system?

Please choose ONE option! (1 out of 4)

| | | |
|----|---|--------------------------|
| a) | Test environment readiness. | <input type="checkbox"/> |
| b) | The ability to log in to the test object by the tester. | <input type="checkbox"/> |
| c) | Defect density does not exceed target and defects have been reported. | <input type="checkbox"/> |
| d) | Requirements are translated into given/when/then format. | <input type="checkbox"/> |

| | | | | |
|-------------|----------|----|-------|-----|
| Question 32 | FL-5.1.4 | K3 | Score | 1.0 |
|-------------|----------|----|-------|-----|

Your team uses the three-point estimation technique to estimate the test effort for a new high-risk feature. The following estimates were made:

- most optimistic estimation: 2 person-hours
- most likely estimation: 11 person-hours
- most pessimistic estimation: 14 person-hours

What is the final estimate?

Please choose **ONE** option! (1 out of 4)

| | | |
|----|-----------------|--------------------------|
| a) | 9 person-hours | <input type="checkbox"/> |
| b) | 10 person-hours | <input type="checkbox"/> |
| c) | 11 person-hours | <input type="checkbox"/> |
| d) | 14 person-hours | <input type="checkbox"/> |

| | | | |
|-------------|----------|----|-----------|
| Question 33 | FL-5.1.5 | K3 | Score 1.0 |
|-------------|----------|----|-----------|

You are testing a mobile application that allows users to find a nearby restaurant based on the type of food they want to eat. Consider the following list of test cases, priorities (i. e., a smaller number means a higher priority), and dependencies:

| Test case number | Test condition covered | Priority | Logical dependency on |
|------------------|------------------------|----------|-----------------------|
| TC 001 | Select type of food | 3 | none |
| TC 002 | Select restaurant | 2 | TC 001 |
| TC 003 | Get directions | 1 | TC 002 |
| TC 004 | Call restaurant | 2 | TC 002 |
| TC 005 | Make reservation | 3 | TC 002 |

Which of the following test cases should be executed as the third one?

Please choose ONE option! (1 out of 4)

| | | |
|----|--------|--------------------------|
| a) | TC 003 | <input type="checkbox"/> |
| b) | TC 005 | <input type="checkbox"/> |
| c) | TC 002 | <input type="checkbox"/> |
| d) | TC 001 | <input type="checkbox"/> |

| | | | | |
|-------------|----------|----|-------|-----|
| Question 34 | FL-5.1.7 | K2 | Score | 1.0 |
|-------------|----------|----|-------|-----|

Consider the following tests (1-4) and testing quadrants (A-D):

1. Usability testing
 2. Component testing
 3. Functional testing
 4. Reliability testing
-
- A. Testing quadrant Q1: technology facing, supporting the team
 - B. Testing quadrant Q2: business facing, supporting the team
 - C. Testing quadrant Q3: business facing, critical consideration of the product
 - D. Testing quadrant Q4: technology facing, critical consideration of the product

How do the following test categories map onto the testing quadrants?

Please choose ONE option! (1 out of 4)

| | | |
|----|----------------|--------------------------|
| a) | 1C, 2A, 3B, 4D | <input type="checkbox"/> |
| b) | 1D, 2A, 3C, 4B | <input type="checkbox"/> |
| c) | 1C, 2B, 3D, 4A | <input type="checkbox"/> |
| d) | 1D, 2B, 3C, 4A | <input type="checkbox"/> |

| | | | | |
|-------------|----------|----|-------|-----|
| Question 35 | FL-5.2.4 | K2 | Score | 1.0 |
|-------------|----------|----|-------|-----|

During a risk analysis the following risk was identified and assessed:

- Risk: Search result response time is too long
- Risk likelihood: medium; risk impact: high
- Response to risk:
 - an independent test team performs performance testing during system testing.
 - a selected sample of end users performs alpha and beta acceptance testing before the release.

What kind of actions were proposed above to respond to the identified risk?

Please choose ONE option! (1 out of 4)

| | | |
|----|------------------|--------------------------|
| a) | Risk acceptance | <input type="checkbox"/> |
| b) | Contingency plan | <input type="checkbox"/> |
| c) | Risk mitigation | <input type="checkbox"/> |
| d) | Risk transfer | <input type="checkbox"/> |

| | | | | |
|-------------|----------|----|-------|-----|
| Question 36 | FL-5.3.2 | K2 | Score | 1.0 |
|-------------|----------|----|-------|-----|

Which of the following statements about the purpose and content of test reports is true?

Please choose ONE option! (1 out of 4)

| | | |
|----|--|--------------------------|
| a) | Test completion reports are prepared and distributed on a regular basis to keep stakeholders up to date on progress. | <input type="checkbox"/> |
| b) | A test progress report includes, among other things, an assessment of the quality of the product and any deviations from the schedule. | <input type="checkbox"/> |
| c) | A test completion report is generated when a test level has been completed and builds on test progress reports and additional data. | <input type="checkbox"/> |
| d) | Test progress reports are generated during test completion to demonstrate that the exit criteria have been met. | <input type="checkbox"/> |

| | | | | |
|-------------|----------|----|-------|-----|
| Question 37 | FL-5.4.1 | K2 | Score | 1.0 |
|-------------|----------|----|-------|-----|

You need to update one of the automated test scripts to align with a new requirement.

Which process dictates that a new version of the test script should be added to the test repository?

Please choose ONE option! (1 out of 4)

| | | |
|----|--------------------------|--------------------------|
| a) | Traceability management | <input type="checkbox"/> |
| b) | Maintenance testing | <input type="checkbox"/> |
| c) | Configuration management | <input type="checkbox"/> |
| d) | Requirements management | <input type="checkbox"/> |

| | | | | |
|-------------|----------|----|-------|-----|
| Question 38 | FL-5.5.1 | K3 | Score | 1.0 |
|-------------|----------|----|-------|-----|

In your role as project lead, you received the following defect report from the developers stating that the anomaly described is not reproducible.

Application hangs up.

ID 713-20230401 2022-May-03 – John Doe – Rejected

The application hangs up after entering "Test input: \$ä" in the Name field on the new user creation screen. I tried logging out and logging in with test_admin01 account, same problem. Tried with other test administrator accounts, same problem. No defect message received; the log (see attachment) contains a fatal defect message. Based on test case TC-1305, the application should accept the provided input and create the user. Please fix this issue with high priority as this feature is related to REQ-0012 which is an important new functional requirement.

What important information is **MISSING** from this test report that would have been useful for the developers?

Please choose **ONE** option! (1 out of 4)

| | | |
|----|---------------------------------------|--------------------------|
| a) | Expected result and actual result | <input type="checkbox"/> |
| b) | References and defect status | <input type="checkbox"/> |
| c) | Test environment and test item | <input type="checkbox"/> |
| d) | Priority and severity (incl. version) | <input type="checkbox"/> |

| | | | | |
|-------------|----------|----|-------|-----|
| Question 39 | FL-6.1.1 | K2 | Score | 1.0 |
|-------------|----------|----|-------|-----|

Which test activity does a data preparation tool support?

Please choose ONE option! (1 out of 4)

| | | |
|----|-----------------------------------|--------------------------|
| a) | Test monitoring and control | <input type="checkbox"/> |
| b) | Test analysis and design | <input type="checkbox"/> |
| c) | Test implementation and execution | <input type="checkbox"/> |
| d) | Test completion | <input type="checkbox"/> |

| | | | | |
|-------------|----------|----|-------|-----|
| Question 40 | FL-6.2.1 | K1 | Score | 1.0 |
|-------------|----------|----|-------|-----|

Which item correctly identifies a potential risk with test automation?

Please choose ONE option! (1 out of 4)

| | | |
|----|---|--------------------------|
| a) | There may be unknown side effects in operational use. | <input type="checkbox"/> |
| b) | Unrealistic expectations regarding functionality of a tool. | <input type="checkbox"/> |
| c) | Test tools may not be reliable enough. | <input type="checkbox"/> |
| d) | The amount of time that is available for manual testing may be reduced in the long run. | <input type="checkbox"/> |

Space for your notes:

(are neither read nor valuated during proofreading)

Space for your notes:

(are neither read nor valuated during proofreading)